

## RF Emissions of Powerline Ethernet adaptors

Tim Williams  
*Elmac Services*

A previous article [1] discussed the issues raised by PLT (Power Line Telecommunications) in the context of EMC. In passing, it mentioned the BT Vision in-home entertainment system. Since that was published, the author has had the opportunity of making some emissions measurements on a pair of Comtrend PowerGrid 902 Powerline Ethernet adaptors, as supplied with every BT Vision package. This article reports the results and discusses their implications.

### ***The BT Vision PLT component***

The BT Vision package [2] is a system provided to a residential customer by which streaming video can be sent down an ADSL (broadband) line and circulated around the customer's house to allow a choice of TV programmes and other video content in each room. The communication around the house is provided by a local area network, and this can be implemented either by wired Ethernet, or wireless networking, or by using a pair or more of adaptors to convert the Ethernet data to a signal that can be passed across the mains power wiring in the house.

The adaptor uses a form of modulation which spreads the data across a spectrum extending from 1.8MHz up to 26.5MHz and applies this spectrum as a differential signal between live and neutral of a standard 13A mains plug. It can be plugged in to any available mains socket, and a mating adaptor elsewhere on the ring main then re-converts the received data to Ethernet format. As supplied, the adaptors are "plug-and-play", that is they will negotiate a link automatically as soon as they are switched on and need no further attention once set up.

The approach is a very convenient and easy-to-implement way of passing broadband data around a house, especially in situations where wireless networking is impossible or inadequate. But unlike other wired and wireless methods, it raises substantial concerns of interference to innocent third-party users of the radio spectrum in the neighbourhood and perhaps beyond. These were discussed in some depth in [1], and here we will concentrate on the performance of the adaptors as actually supplied.

### ***Measurements on the Comtrend adaptors***

Two adaptors taken from a supplied BT Vision package have been measured in a standard CISPR conducted emissions measurement set-up. The configuration used is shown in Figure 1 and is compliant with the usual CE test as described in CISPR22/EN55022 and familiar to all EMC test labs. In order to ensure a clear communication channel the two units were plugged into a single multi-socket strip which was itself plugged into the LISN (CISPR 50 ohm/50µH V-network) via a 1m cable length. This should give the most favourable conditions for the devices, since there is virtually no path loss, no interference, and a flat, defined differential mode impedance of 100 ohms. The Ethernet port of one unit was connected to a battery-powered laptop via a short (50cm) UTP cable, located next to the test units; that of the other unit was connected to the local Ethernet router via a 2m UTP cable. File transfer could be initiated across the Ethernet link to test the adaptors' emissions in standby mode or when communicating continuous data.

The measuring instrument was an Advantest R4131B spectrum analyser. The measurement method was exactly as described in CISPR22:2005, that is, the voltage levels across Live to Earth and across Neutral to Earth were measured separately and the maximum value at each frequency taken. The significance of this will become clear later.

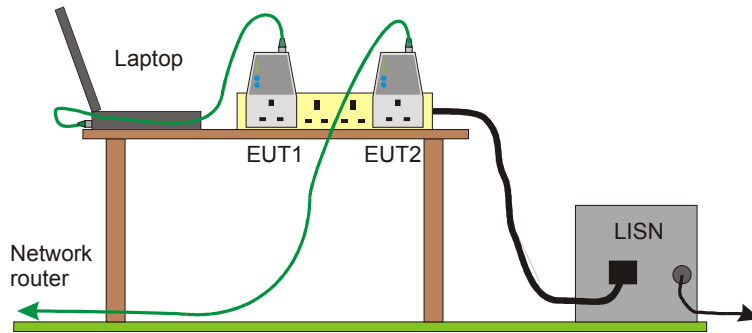

**Figure 1 Schematic of the measurement set-up**

The results compared against the class B (residential) QP limits are shown in Figure 2, and those compared against the Class B average limits are shown in Figure 3. Measurements were made beyond the CE top frequency of 30MHz, to see if there were any emissions that might fall into the radiated frequency band, although radiated emissions testing was not performed. Three sets of data are shown in each plot; with the units plugged in but switched off (the STATUS LED showing red), labelled “quiescent”; with the units in standby, i.e. with all LEDs showing green but not transferring data; and with continuous file transfer taking place across the link. Quasi-peak measurements were made at spot frequencies, as is typical test house practice, shown by diamonds on the plots.

To check the effect of the test set-up, the Ethernet links were separately disconnected in standby mode and the laptop was moved relative to the test ground plane. No effect on the measured levels was seen, showing that these were generated across the Live and Neutral terminals with no reference to the Ethernet port or to the ground plane. This was confirmed by using the LISN diagnostically to show that the emissions were largely in differential mode ( $L - N$ ) rather than in common mode ( $LN - E$ ). Values at all frequencies were essentially identical on both Live and Neutral lines.

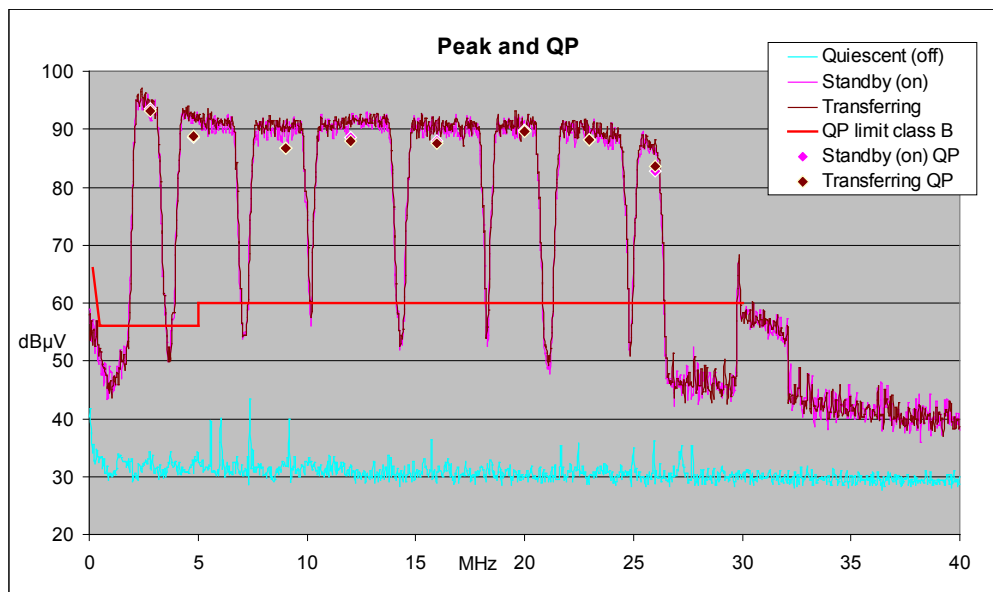

**Figure 2 Conducted emissions: peak and quasi-peak**

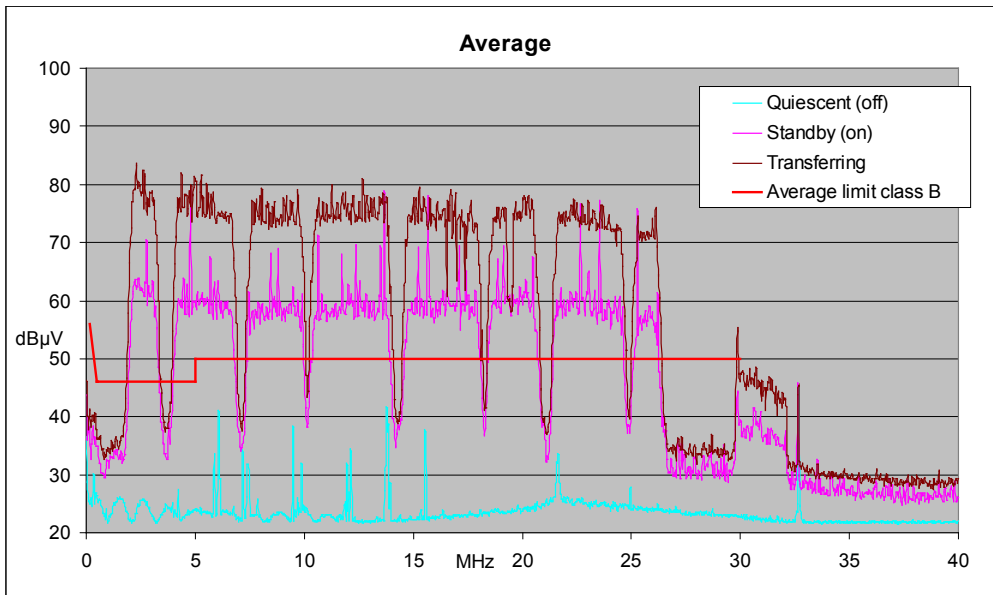

**Figure 3 Conducted emissions: average**

NB spikes visible on the quiescent trace are local ambients, not caused by the adaptor

The headline result here is that for both average and quasi-peak limits, the system is approximately 30dB over the CISPR limit, not at isolated frequencies but over large swathes of the conducted emissions range, with notches to below the limit at certain frequencies. When not transferring data the average level drops, though still well above the limit, but in QP there is essentially no difference as to whether the unit is transferring or not. Unless the user deliberately switches the units off – in which case the products are comfortably compliant, illustrated by the “quiescent” trace – they will be putting out the full signal level 24 hours a day.

### Notches

The notches in the emitted spectrum fall below the limit at frequencies which roughly correspond to the UK amateur bands at 3.5MHz, 7MHz, 14MHz, 18MHz and 21MHz. (US amateur bands, not available in Europe, are also included.) These are shown in Figure 4.

**Figure 4 Notches at various frequencies**

The yellow lines correspond to the UK amateur bands

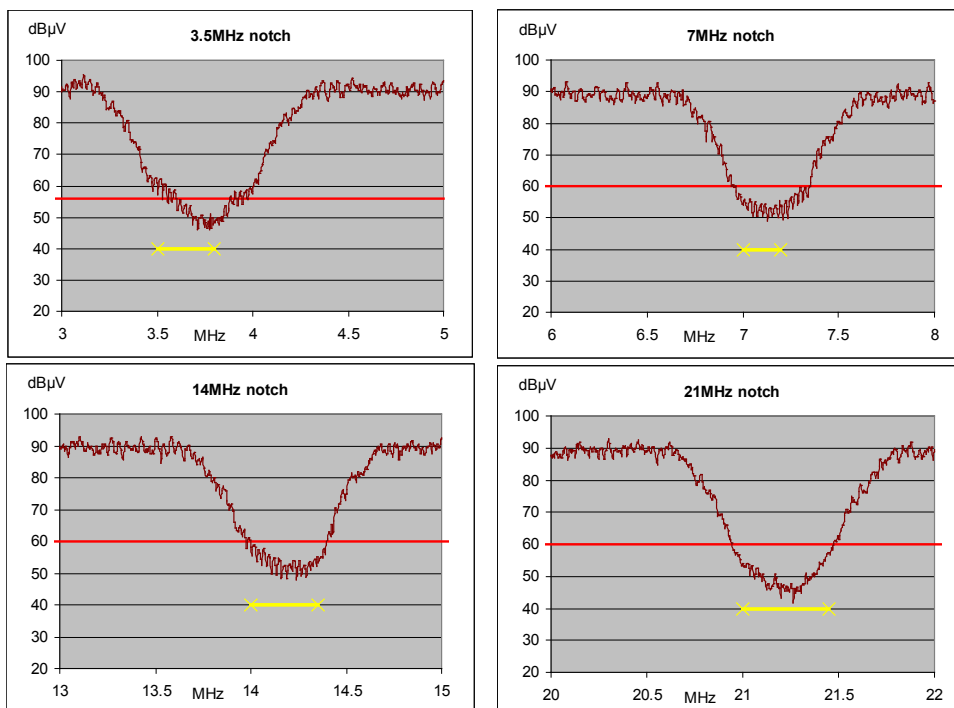

These notches are as supplied from the factory and cannot be changed; also as supplied, by default there is a specific exclusion for the frequency range 26.5-28MHz which is to prevent interference to wireless mouse connections, which use the 27.12MHz free radiation frequency. This can be disabled via the unit's web user interface, in which case the emissions extend up to 28MHz, and this has indeed been found experimentally to interfere with a wireless mouse in the vicinity. It is also possible to insert extra custom notches via this interface, with a concomitant reduction in data transfer rate. Whilst a technically able user could do this in order to mitigate a case of interference at a specific frequency, it would be unreasonable to suggest this as a default method of interference control in the hands of a naïve user.

The web user interface also shows that power control is enabled on both units as supplied, but there is no indication that the power level is being adjusted in real time to minimise the amount of RF passed into the mains.

The use of notches creates a further issue of concern, which is intermodulation. The plots in the figures above were taken without a transient limiter in circuit in the LISN. Figure 5 below shows the effect of switching in a limiter, as may be standard practice in some test labs to protect the front end of the measuring instrument. In the measurement system shown, the limiter is a pair of back-to-back silicon diodes preceded by a few dB of attenuation, which imply a clipping threshold of around 1V at the measurement point. The effect of a limiter in general EMC testing was discussed in [3]. In Figure 5, it can be seen that the limiter raises the apparent noise floor of the measurement to 70dB $\mu$ V and "fills in" the notches. This is because the intermodulation generated by the non-linearity of the limiter creates frequency components that were not present in the original signal; if the original signal is broadband, the intermodulation will cover all frequencies that were notched, including those above the source spectrum, as is evident in Figure 5.

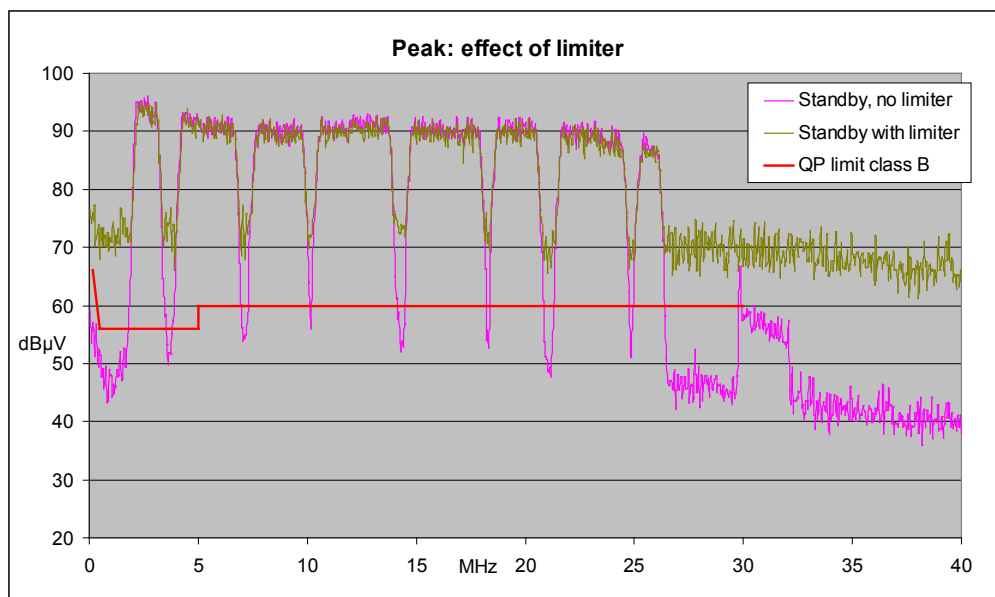

**Figure 5 The effect of intermodulation from a transient limiter**

This is an artefact of the measurement system; the total peak amplitude of hundreds of mV is quite sufficient to push a standard limiter into non-linearity. However, it is relevant to a PLT installation since any mains network is likely to include a variety of non-linear devices, principally the rectifier diodes at the input of any connected electronic apparatus or the triacs in, for instance, lighting dimmers. So that, although intermodulation should be guarded against in the measurement set-up, it is dangerous to rely on notches to protect any part of the radio spectrum since in real life, and depending on the individual installation, the unavoidable non-linearities will defeat their purpose.

## **Discussion**

These measurements lead to the unavoidable conclusion that the Comtrend PG902 adaptor exceeds the allowable limits in CISPR 22/EN 55022 by a factor of 30dB, continuously, over the majority of the frequency range. Any reputable manufacturer of electronic equipment would not market such a device until it had been redesigned and brought into compliance. Yet, British Telecom are supplying these units

in their hundreds of thousands to BT Vision subscribers, and in October 2008 extended their contract with Comtrend to continue supplying them for a second year [4]. The adaptors are CE Marked, implying that their manufacturer believes that they are compliant with the appropriate European Directives. How can this discrepancy be explained?

A clue lies in the declaration of conformity that Comtrend place in their user guide for the PowerGrid 902 model [5]. Within this DoC we find the following:

*(reference to EN 55022:2006)*

*Other specifications and Technical Documentation:*

*CIS/I/89/CD Amendment to CISPR 22: Clarification of its application to telecommunication system on the method of disturbance measurement at ports used for PLC (Power Line Communication)*

*PowerGrid 902 TCF Technical Construction File of PowerGrid 902 ref. PG902CTTCF0508v1*

*This Certificate is guarantee by the following support documentation:*

...

*CISPR I/89/CD Test Report IE\_ICEM\_COM080101-IN issued by ENAC accredited laboratory 190/LE1113-4 ITACA and therefore complies with the essential requirements and provisions of the EMC and LV Directives*

## CISPR/I/89/CD

The reference to CISPR/I/89/CD is significant. This was a draft document [6] circulated for comment in November 2003 by CISPR in an attempt to create a mechanism within CISPR 22 that would allow PLT devices to comply directly with it. It was rejected before being developed further; as discussed in [1], later developments included a new document, CISPR/I/257/CD, which has also been rejected in turn. As is usual with draft documents, CISPR/I/89/CD includes the standard warning “THIS DOCUMENT IS STILL UNDER STUDY AND SUBJECT TO CHANGE. IT SHOULD NOT BE USED FOR REFERENCE PURPOSES.” Nevertheless, some Competent (now Notified) bodies in Europe have used it as the basis for an opinion, and this is clearly the case here: ITACA is an accredited EMC test lab (although, to be clear, not accredited against CISPR/I/89/CD, and therefore referring to them as an “ENAC accredited laboratory” in this context is irrelevant) in Valencia, Spain who have apparently taken this approach in agreeing Comtrend’s Technical Construction File.

The method proposed in CISPR/I/89/CD relied on the balance of the mains supply when used for RF broadband communication. Its introductory note stated that

*The current document is based on the principle that PLC equipment must have a positive signal to noise ratio in order to function, and therefore must be allowed higher signal levels on the power mains. The interference potential at the multi purpose port is thus measured twice:*

*1) in its function as a power consumer (i.e. communication function disabled) using the familiar V-network and limits in tables 1 and 2 of CISPR 22 and;*

*2) in its function as telecom device using the T-network specified within this document and applying the limits in tables 3 and 4 of CISPR 22.*

*National committees are advised that this application of separate limits for the different functions is a new approach in CISPR/I and are asked to comment on this approach.*

The first sentence was highly controversial and most probably contributed to the document’s failure, but in the context of the PG902 adaptor the technical basis was also unacceptable. Clearly, if the device is disabled but still consuming power it satisfies case 1) above and, as can be seen from the plots shown earlier, it easily meets the normal limits of CISPR 22. But for the PG902 the distinction between “disabled” and “standby” is vital; when turned on, the unit operates 24 hours a day in standby mode and is putting out its full spectrum signal even though it is not transferring data. The “communication function disabled” state is irrelevant in the real world.

Case 2) refers to “the T-network specified within this document” and this is a network with a flat longitudinal conversion loss (LCL) of  $30 \pm 6\text{dB}$  (see [1] for an explanation of LCL). This author has not been able to measure the samples with this network to see if they meet the limits referred to in case 2). Because no published standard has specified such a network it is not commercially available, although an enterprising test lab could undoubtedly construct one. But given that the signal is applied differentially between live and neutral, emissions which appear at the levels shown in the plots above when measured with a normal LISN could indeed just about meet the telecom port limits when measured with a T-network of LCL  $30 \pm 6\text{dB}$ . Therefore, taking CISPR/I/89/CD at face value as a contribution to an EMC Technical Assessment according to the EMC Directive, it is possible that the PG902 could be shown to comply with it.

But CISPR/I/89/CD cannot be taken at face value. Apart from being rejected in CISPR, it included a statement which effectively torpedoed even what limited merit it may have had. Describing the specification for the T-network, it states (and the sentiment is repeated in the introductory note)

*This ISN is only representative for low voltage distribution networks where the two conductors, usually Phase and Neutral, that are being symmetrically driven by the PLC equipment are cabled together. This ISN is not appropriate for representing networks where one of the driven conductors is run independently of the other driven conductor as may be the case in some remotely switched circuits.*

Such independently run mains wiring is commonplace, at least in the UK, where for instance the live wire can be run away from its neutral return to a light switch or other switching circuit, and back again. This effectively unbalances the phase and neutral conductors and negates the assumption of a  $30\text{dB}$  LCL. So any measurements to CISPR/I/89/CD cannot be used to offer a justification for compliance of a product that is used in UK residential properties. Again, this would have been a reason for rejection of the document within CISPR/I.

## Consequence of excessive emissions

What are the consequences for such an egregious disregard for limits accepted as mandatory by all other manufacturers of electrical and electronic equipment, especially when the unit in question is supplied in volume by the largest telecom utility in the UK?

Firstly, is there an actual interference problem? Continuously exceeding the limits by  $30\text{dB}$  suggests this might be expected, and indeed it is easy to demonstrate that HF broadcast reception is seriously affected by the operation of the adaptors (audio recordings of this interference can be found at the Elmac Services website, [www.elmac.co.uk](http://www.elmac.co.uk)). But more than this, the spread of BT Vision has given rise to a protest group, UKQRM, whose reported discussions with Ofcom, the regulator, can be found on their website [7]. Their on-line petition calling for an immediate ban on power line adaptors of the type currently supplied by BT has attracted 3,500 signatures, suggesting that experience of interference problems is indeed widespread.

Secondly, what kind of message does this give about official attitudes to the EMC Directive? Make no mistake, BT wields very considerable clout in CISPR, and is no stranger to the EMC world. Most of the readers of the EMC Journal will be compliance engineers in companies that have elected to make sure their products comply with the pan-European standards harmonised for the EMC Directive. This is because there is a legal requirement on them to do so. EMC is not a lightweight discipline; considerable effort and cost is needed in both design and testing to confirm that the standards are indeed met. If BT appear to be able to ignore these standards, in placing on the market to the end user a high-volume product which clearly does not meet them, what is the worth of other companies continuing to make these efforts?

## References

- [1] *Why broadband PLT is bad for EMC*, Tim Williams, Elmac Services, EMC Journal January 2009 Issue 80 pp 25-34
- [2] [www.bt.com/vision](http://www.bt.com/vision)
- [3] *The hazard of the transient limiter*, Tim Williams, Elmac Services, EMC Journal March 2007 Issue 69 pp 22-24
- [4] *BT Vision Extends Comtrend Power Line Deal*, Jan Harris, IPTV Watch, October 29, 2008

- [5] *PowerGrid 902 Quick User Guide for UK*, Comtrend, p.14; from [www.comtrend.com](http://www.comtrend.com); DoC dated 24<sup>th</sup> April 2008
- [6] CISPR/I/89/CD, *Amendment to CISPR 22: Clarification of its application to telecommunication system on the method of disturbance measurement at ports used for PLC (Power Line Communication)*, CISPR/I, 14<sup>th</sup> November 2003
- [7] [www.ukqrm.org](http://www.ukqrm.org)

This article was first published in the EMC Journal, Issue 82 May 2009, pp 15-18  
<http://www.theemcjournal.com>

Tim Williams is with Elmac Services, Wareham, Dorset, UK  
<http://www.elmac.co.uk>